



**ARTEC**  
PNEUMATIC COMPONENTS  
made in Italy  
P: Max 10 bar  
prod: 17-14  
**M20DEM**  
www.artec-pneumatic.com

SERIE

**M**

**PINZE PNEUMATICHE**  
**PNEUMATIC GRIPPERS**



**CARATTERISTICHE TECNICHE - TECHNICAL CHARACTERISTICS**

<b>Pressione di esercizio</b> <i>Working pressure</i>	max 10 bar
<b>Temperatura di esercizio</b> <i>Working temperature</i>	0 ÷ +80°C (-20°C con aria secca - <i>with dry air</i> )
<b>Versioni - Versions</b>	semplice effetto, doppio effetto - <i>single acting, double acting</i>
<b>Alesaggi - Bores</b>	∅ 16 - 20 - 32 - 50
<b>Fluido - Fluid</b>	aria compressa filtrata, non lubrificata - <i>compressed filtered, non lubricated air</i>

**CARATTERISTICHE COSTRUTTIVE - CONSTRUCTIVE CHARACTERISTICS**

①	<b>Griffa - Jaw</b>	acciaio temprato - <i>tempered steel</i>
②	<b>Stelo - Rod</b>	acciaio inox AISI 303 - <i>AISI 303 stainless steel</i>
③ ④	<b>Perno - Pin</b>	acciaio temprato - <i>tempered steel</i>
⑤	<b>Corpo - Housing</b>	alluminio anodizzato - <i>anodized aluminium</i>
⑥ ⑧ ⑫	<b>Guarnizioni - Seals</b>	NBR
⑦	<b>Pistone - Piston</b>	alluminio - <i>aluminium</i>
⑨	<b>Magnete - Magnet</b>	plastoferrite - <i>rubber magnet</i>
⑩	<b>Testata - Cover</b>	ottone - <i>brass</i>
⑪	<b>Seeger - Retaining ring</b>	acciaio - <i>steel</i>
	<b>Molla - Spring</b>	acciaio - <i>steel</i>

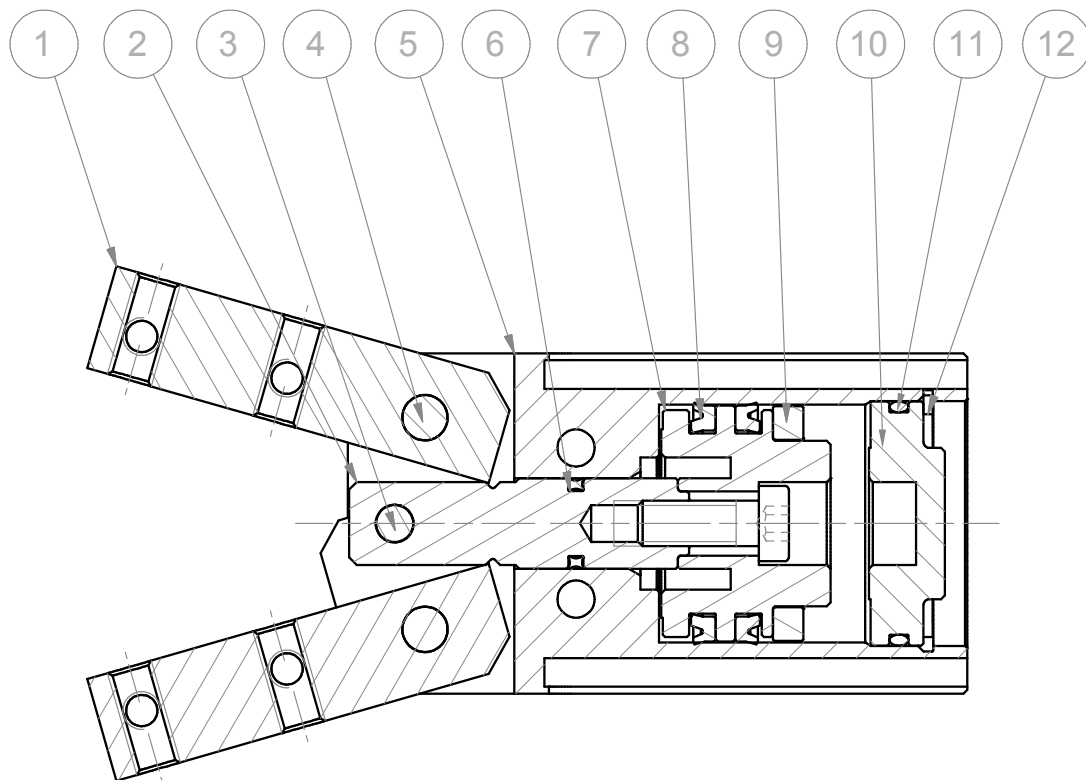

## CHIAVE DI CODIFICA

### KEY CODE

M 2 0 D E M

#### VERSIONE - VERSION

<b>NA</b>	normalmente aperta - molla posteriore <i>normally open - rear spring</i>
<b>NAM</b>	normalmente aperta magnetica - molla posteriore <i>normally open magnetic - rear spring</i>
<b>NC</b>	normalmente chiusa - molla anteriore <i>normally closed - front spring</i>
<b>NCM</b>	normalmente chiusa magnetica - molla anteriore <i>normally closed magnetic - front spring</i>
<b>DE</b>	doppio effetto <i>double acting</i>
<b>DEM</b>	doppio effetto magnetico <i>double acting magnetic</i>
<b>DEP</b>	doppio effetto con perno posteriore <i>double acting with rear pin</i>

#### ALESAGGIO - BORE (Ø)

016-020-032-050

#### SERIE - SERIES

**M** pinza pneumatica ad apertura angolare  
*pneumatic angular gripper*

## FORZA TEORICA DI BLOCCAGGIO (P=6bar)

### THEORETICAL LOCKING FORCE (P=6bar)

COD.	FORZA DI BLOCCAGGIO [KG] LOCKING FORCE [KG]	PRESSIONE DI ESERCIZIO [BAR] WORKING PRESSURE [BAR]
M16NA - M16NAM	4	2,5 ÷ 10
M16NC - M16NCM	5,2	2,5 ÷ 10
M16DE - M16DEM	5,5 - 6,5	1,5 ÷ 10
M20NA - M20NAM	7,5	2 ÷ 10
M20NC - M20NCM	8,5	2 ÷ 10
M20DE - M20DEM	10,1 - 12,2	1,5 ÷ 10
M32NA - M32NAM	16,5	2 ÷ 10
M32NC - M32NCM	19,5	2 ÷ 10
M32DE - M32DEM	22 - 24	1,5 ÷ 10
M50NAM	46	2 ÷ 10
M50NCM	49	2 ÷ 10
M50DEM	52 - 60	1,5 ÷ 10

La forza di bloccaggio è calcolata alla distanza di 15mm dal fulcro delle griffe; a 30mm per M50.

The locking force is calculated at a distance of 15 mm from the jaws fulcrum; as to M50, the distance is 30mm.



**PINZE PNEUMATICHE**

**M16DEP**

**PNEUMATIC GRIPPERS**

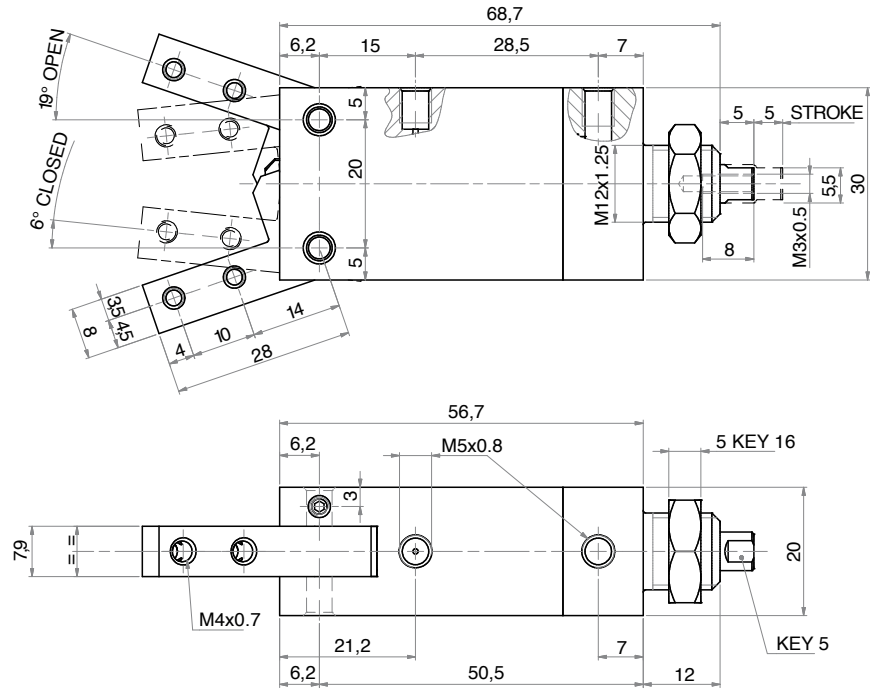
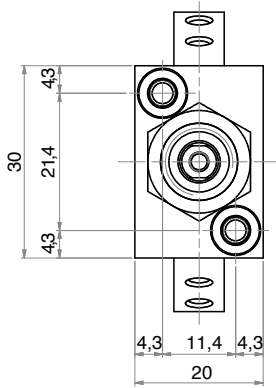

**PINZE PNEUMATICHE**

**M20DE**

**M20NA**

**M20NC**

**PNEUMATIC GRIPPERS**

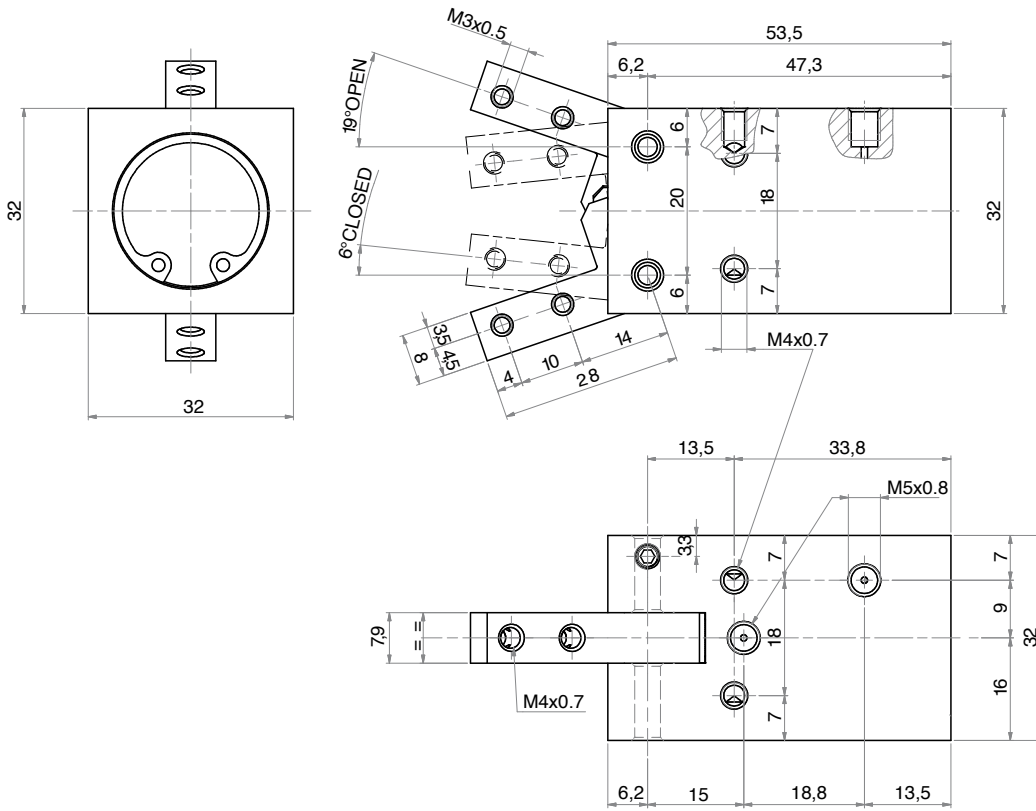

**PINZE PNEUMATICHE**

**M20DEM**

**M20NAM**

**M20NCM**

**PNEUMATIC GRIPPERS**

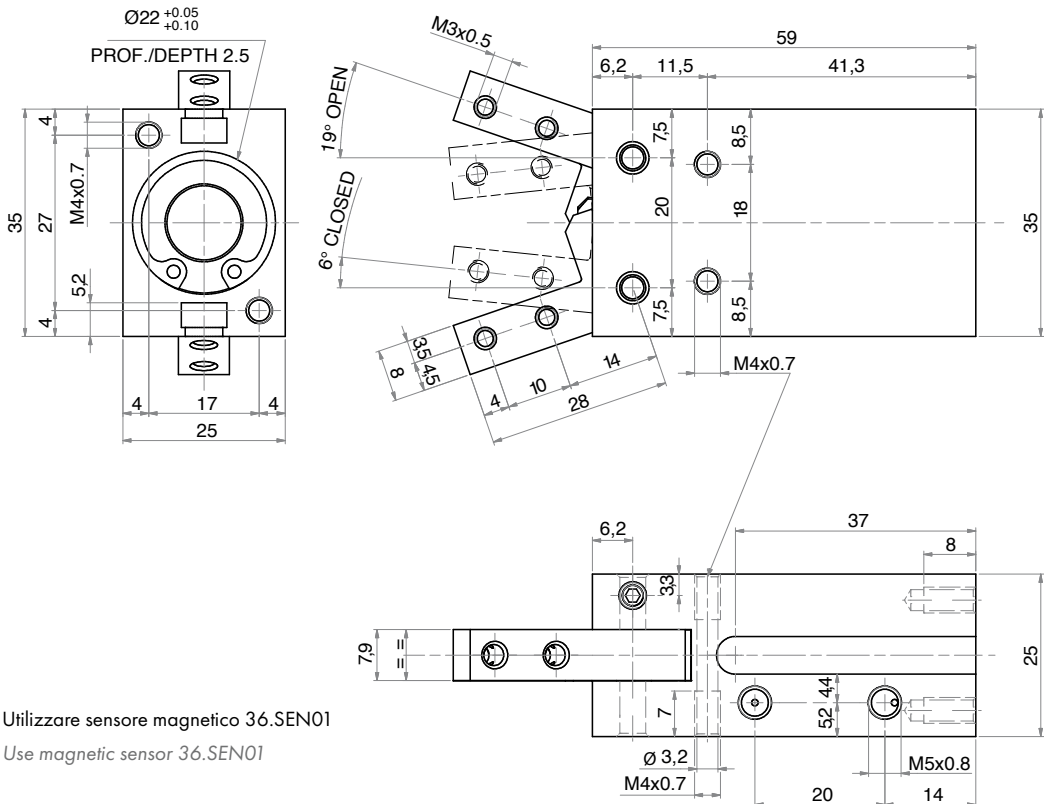

!!!: Utilizzare sensore magnetico 36.SEN01

!!!: Use magnetic sensor 36.SEN01



**PINZE PNEUMATICHE**

**M32DE**

**M32NA**

**M32NC**

**PNEUMATIC GRIPPERS**

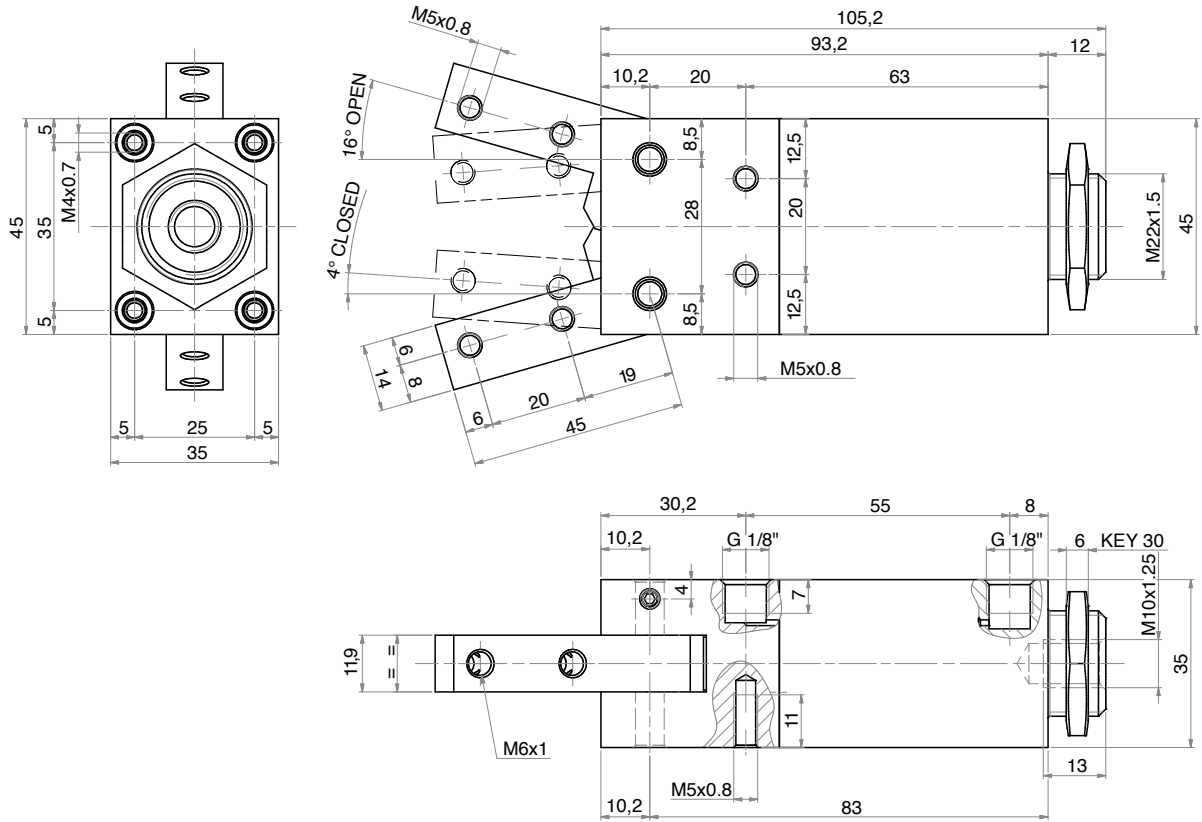

**PINZE PNEUMATICHE**

**M32DEM**

**M32NAM**

**M32NCM**

**PNEUMATIC GRIPPERS**

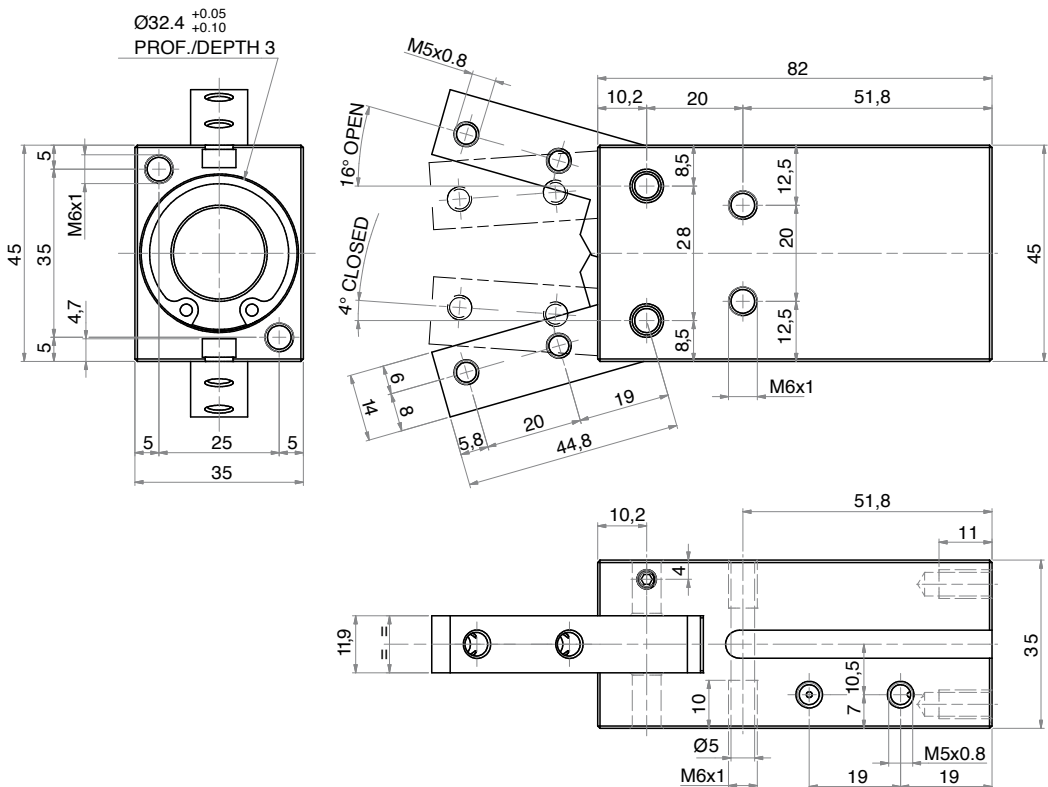



**PINZE PNEUMATICHE**

**M32DEP**

**PNEUMATIC GRIPPERS**

