

SERIE

**F**

**CILINDRI CORSA BREVE**  
**SHORT STROKE CYLINDERS**

  
**ARTEC**<sup>®</sup>  
PNEUMATIC COMPONENTS

### CARATTERISTICHE TECNICHE - TECHNICAL CHARACTERISTICS

<b>Pressione di esercizio</b> <i>Working pressure</i>	1 ÷ 10 bar (doppio effetto - <i>double acting</i> ) 2 ÷ 10 bar (semplice effetto - <i>single acting</i> )
<b>Temperatura di esercizio</b> <i>Working temperature</i>	0 ÷ +80 °C (-20 °C con aria secca - <i>with dry air</i> ) 0 ÷ +150 °C (con guarnizioni per alte temperature - <i>with high temperature seals</i> )
<b>Versioni - Versions</b>	semplice effetto - doppio effetto - antirotazione - stelo passante <i>single acting - double acting - anti-rotation - double rod</i>
<b>Alesaggi - Bores</b>	∅ 12 - 16 - 20 - 25 - 32 - 40 - 50 - 63 - 80 - 100
<b>Corse - Strokes</b>	vedere tabelle corse standard - <i>see standard stroke tables</i>
<b>Fluido - Fluid</b>	aria compressa filtrata, non lubrificata - <i>compressed filtered, non lubricated air</i>

### CARATTERISTICHE COSTRUTTIVE - CONSTRUCTIVE CHARACTERISTICS

①	<b>Stelo - Rod</b>	acciaio inox AISI 303 - <i>stainless steel AISI 303</i>
② ⑨	<b>Guarnizioni - Seals</b>	poliuretano - <i>polyurethane</i>
③	<b>Boccola - Bush</b>	acciaio+PTFE - <i>steel+PTFE</i>
④	<b>Seeger - Retaining ring</b>	acciaio - <i>steel</i>
⑤	<b>O-ring</b>	NBR
⑥ ⑬	<b>Testate - Covers</b>	∅ 12÷25 ottone - <i>brass</i> ∅ 32÷100 alluminio anodizzato - <i>anodized aluminium</i>
⑦	<b>Tubo - Tube</b>	alluminio anodizzato - <i>anodized aluminium</i>
⑧ ⑭	<b>Paracolpo - Bumper</b>	Vulkollan
⑩ ⑫	<b>Pistone - Piston</b>	delrin - <i>delrin</i> alluminio - <i>aluminium</i>
⑪	<b>Magnete - Magnet</b>	plastoferrite - <i>rubber magnet</i>
	<b>Molla - Spring</b>	acciaio - <i>steel</i>

SERIE

F

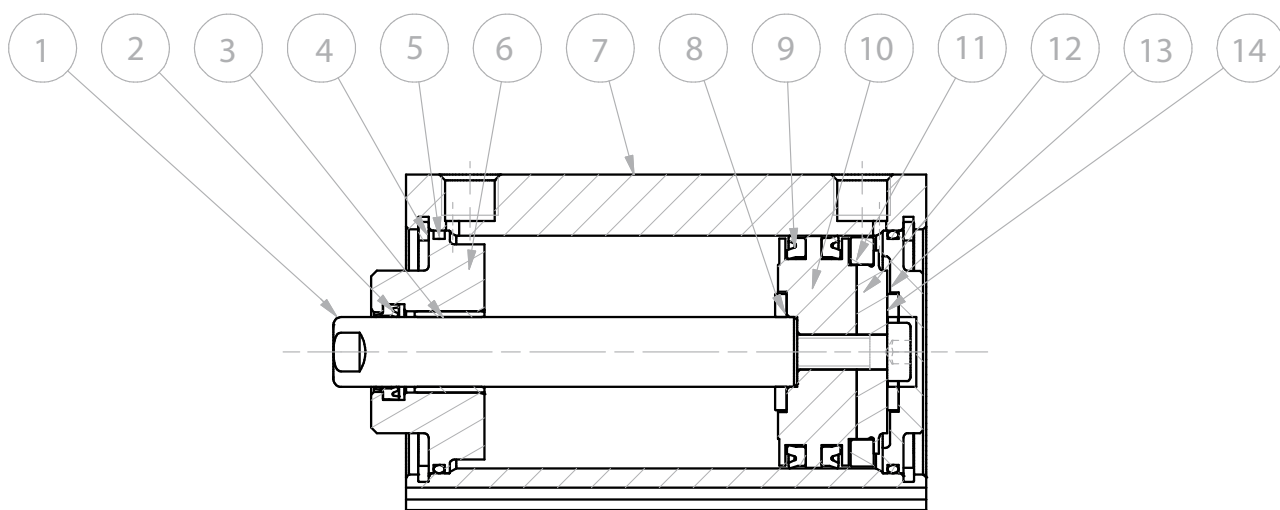

## CHIAVE DI CODIFICA

### KEY CODE

F D M 0 5 0 . 0 3 0 . G S . F .

		<b>ALESAGGIO BORE (Ø)</b>	<b>CORSA STROKE (mm)</b>			<b>OPZIONE - OPTION</b>
		012-016-020-025-032040-050 -063-080-100	vedere tabelle corse std see std stroke tables			<b>CP</b> cerniera posteriore montata hinge rear mounted
<b>VERSIONE - VERSION</b>						
<b>SR</b>	semplice effetto molla anteriore single acting front spring					
<b>SM</b>	semplice effetto magnetico molla anteriore single acting magnetic front spring					
<b>SE</b>	semplice effetto molla posteriore single acting rear spring					
<b>SEM</b>	semplice effetto molla posteriore magnetico single acting magnetic rear spring					
<b>DR</b>	doppio effetto double acting					
<b>DM</b>	doppio effetto magnetico double acting magnetic					
<b>DA</b>	doppio effetto antirotazione double acting anti-rotation					
<b>DMA</b>	doppio effetto magnetico antirotazione double acting magnetic anti-rotation					
<b>DP</b>	doppio effetto stelo passante double acting with double rod					
<b>DMP</b>	doppio effetto magnetico stelo passante double acting magnetic with double rod					
<b>DPA</b>	doppio effetto stelo passante antirotazione double acting anti-rotation with double rod					
<b>DMPA</b>	doppio effetto magnetico stelo passante antirotazione double acting magnetic anti-rotation with double rod					
<b>STELO - ROD</b>						
<b>F</b> femmina female						
<b>OPZIONE - OPTION</b>						
<b>S</b> seeger inox stainless steel retaining ring						
<b>GUARNIZIONI - SEALS</b>						
<b>GS</b> guarnizioni standard standard seals						
<b>VR</b> guarnizione stelo per alte temperature high temperature rod seal						
<b>VA</b> tutte le guarnizioni per alte temperature all seals for high temperature						
<b>SERIE - SERIES</b>						
<b>F</b> tubo profilato con cave per sensori tube with slots for sensors						

SERIE

F

### ESECUZIONI A RICHIESTA - ON REQUEST

Stelo forato - *Hollow rod*

Stelo prolungato (W) - *Extended rod (W)*

Filetti speciali (se stelo maschio dado stelo non fornito) - *Special thread (if male rod without rod nut)*

## FORZE TEORICHE DI TRAZIONE (P=6bar)

### THEORETICAL FORCES OF TRACTION (P=6bar)

		∅	012	016	020	025	032	040	050	063	080	100
<b>FSR FSM</b>	IN SPINTA IN PUSH	[N]	51	106	170	258	441	729	1.070	1.720	2.880	4.440
	IN TIRO IN PULL	[N]	5	6	6	13	18	20	40	49	76	131
<b>FDR FDM</b>	IN SPINTA IN PUSH	[N]	58	114	176	277	462	763	1.110	1.770	2.990	4.650
	IN TIRO IN PULL	[N]	42	84	129	230	392	663	990	1.650	2.800	4.370
<b>FDA FDMA</b>	IN SPINTA IN PUSH	[N]	-	-	173	272	454	750	1.110	1.750	2.970	4.620
	IN TIRO IN PULL	[N]	-	-	123	225	385	653	980	1.630	2.770	4.330
<b>FDP FDMP</b>	IN SPINTA IN PUSH	[N]	42	84	129	230	392	663	990	1.650	2.800	4.370
	IN TIRO IN PULL	[N]	42	84	129	230	392	663	990	1.650	2.800	4.370

SERIE

**F**

## ESEMPIO DI FISSAGGIO

### FIXING EXAMPLE

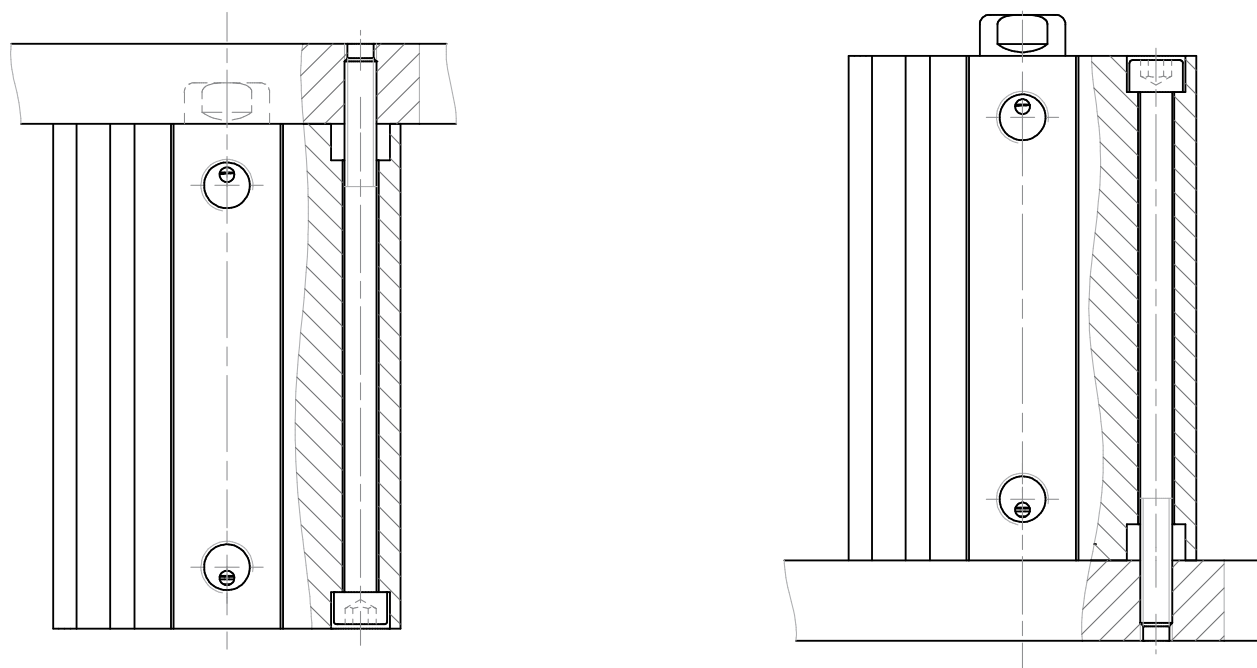

!!! Il fissaggio deve avvenire mediante viti amagnetiche passanti attraverso il cilindro  
 !!! The fixing must be with non-magnetic screws through the cylinder

## PROFILO ESTRUSO DI ALLUMINIO

### EXTRUDED ALUMINIUM PROFILE

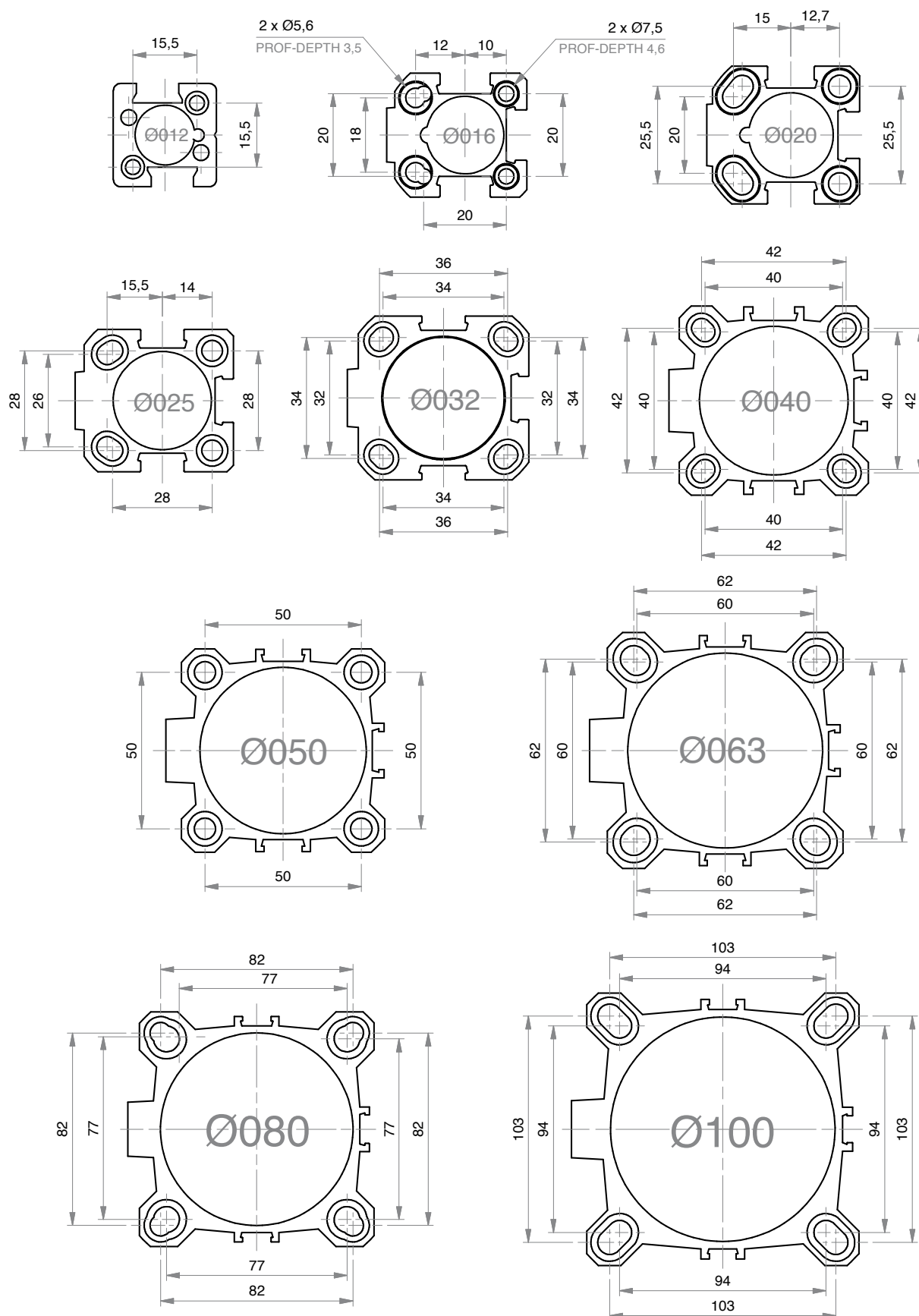

SERIE

F

**SEMPLICE EFFETTO - MOLLA ANTERIORE**

**SINGLE ACTING - FRONT SPRING**

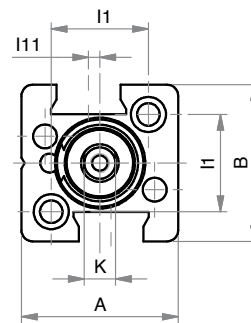
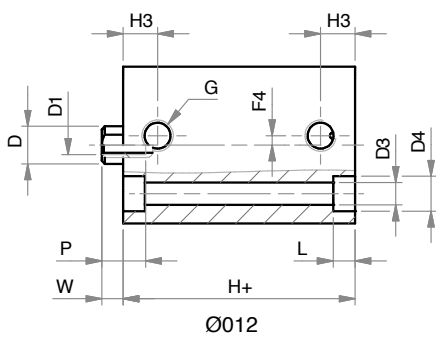
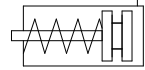

SERIE  
**F**

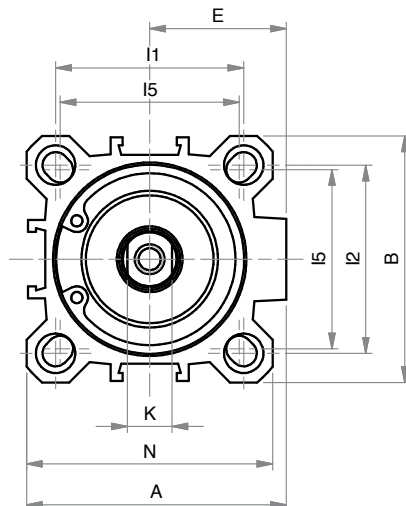
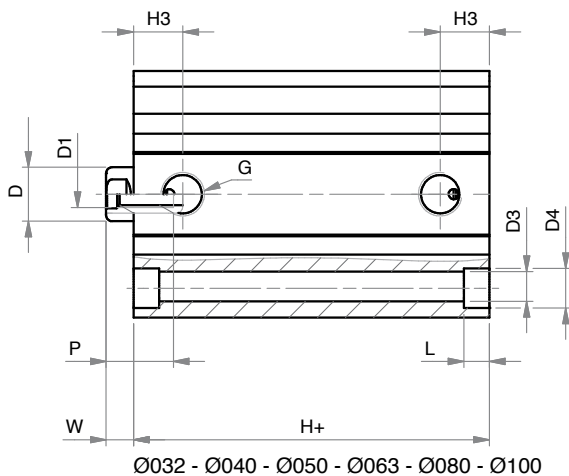
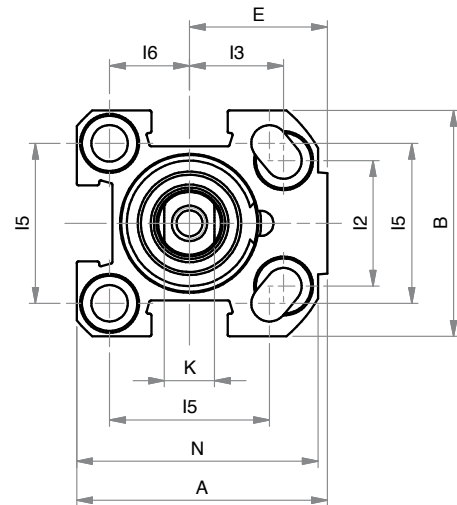
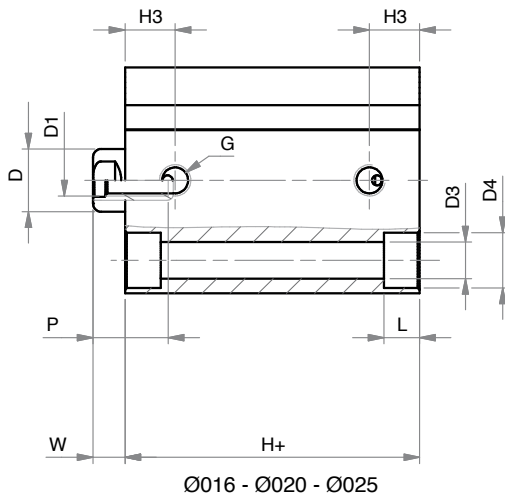

**SEMPLICE EFFETTO - MOLLA ANTERIORE**
**FSR**
**SINGLE ACTING - FRONT SPRING**

<b>DIMENSIONI - DIMENSIONS</b>										
<b>Ø</b>	<b>012</b>	<b>016</b>	<b>020</b>	<b>025</b>	<b>032</b>	<b>040</b>	<b>050</b>	<b>063</b>	<b>080</b>	<b>100</b>
<b>A</b>	25	34	40	44,5	51	58	70	89	105	131
<b>B</b>	25	30	36	40	46	55	65	80	100	124
<b>Ø D</b>	6	8	10	10	12	12	16	16	20	25
<b>D1</b>	M3	M4	M5	M5	M6	M6	M8	M8	M10	M12
<b>Ø D3</b>	3,7	**	5,8	5,8	5,8	5,8	6,8	9	9	11
<b>Ø D4</b>	5,6	**	9	9	9	9	11	14	14	17,2
<b>E</b>	-	19	22	24,5	27	30,5	37,5	46	55	69
<b>G</b>	M5	M5	M5	G1/8	G1/8	G1/8	G1/8	G1/8	G1/4	G1/4
<b>H+</b>	17***	27	27	28,5	29,5*	29,5*	34,5*	37*	46*	56*
<b>H3</b>	5,5	8	8	10,5	11,5	11	11,5	11	14	16
<b>I1</b>	15,5	-	-	-	36	42	50	62	82	103
<b>I2</b>	-	18	20	26	32	42	50	62	82	103
<b>I3</b>	-	12	15	15,5	-	-	-	-	-	-
<b>I5</b>	-	20	25,5	28	34	40	50	60	77	94
<b>I6</b>	-	10	12,7	14	-	-	-	-	-	-
<b>K</b>	5	6	8	8	10	10	13	13	17	22
<b>L</b>	3,5	4,6	5,7	5,7	5,7	5,7	6,8	8,8	9	11
<b>L1</b>	-	3,5	5,7	5,7	-	-	-	-	-	-
<b>N</b>	-	32	38,5	42	48	55	65	80	100	124
<b>P</b>	7	11	12	12	15	15	17	17	17	22
<b>W</b>	3,5	4,5	5	5,5	6	6	7,5	7	8	10

+ = aggiungere lunghezza corsa (mm) - add stroke length (mm)

\* per corse - for strokes 040 - 050:

Ø 032-040-050-063-080-100 aggiungere - add +10 mm

\*\* vedi quote pagina 157 - see dimensions page 157

\*\*\* per corse - for strokes 15-20-25

Ø 12 aggiungere - add + 5 mm

<b>Ø</b>	<b>CORSE STANDARD - STANDARD STROKES</b>
<b>012</b>	5 - 10 - 15 - 20 - 25
<b>016</b>	5 - 10 - 15 - 20 - 25
<b>020</b>	5 - 10 - 15 - 20 - 25
<b>025</b>	5 - 10 - 15 - 20 - 25
<b>032</b>	5 - 10 - 15 - 20 - 25 - 30 - 40 - 50
<b>040</b>	5 - 10 - 15 - 20 - 25 - 30 - 40 - 50
<b>050</b>	10 - 15 - 20 - 25 - 30 - 40 - 50
<b>063</b>	10 - 15 - 20 - 25 - 30 - 40 - 50
<b>080</b>	10 - 15 - 20 - 25 - 30 - 40 - 50
<b>100</b>	10 - 15 - 20 - 25 - 30 - 40 - 50

!!!: Le corse intermedie vengono realizzate con il corpo della corsa standard superiore e con distanziale interno per limitarne la corsa a quella richiesta.

Intermediate strokes are made with the profile of the standard superior stroke and with an internal spacer which limits the stroke to the required one.

SERIE

**F**

**SEMPLICE EFFETTO MAGNETICO - MOLLA ANTERIORE**

**MAGNETIC SINGLE ACTING - FRONT SPRING**

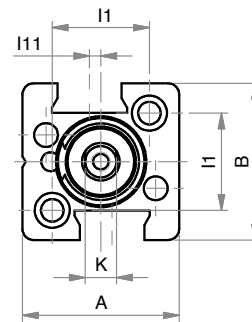
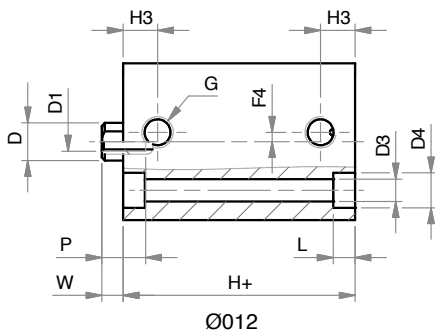
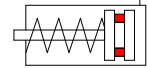

SERIE  
**F**

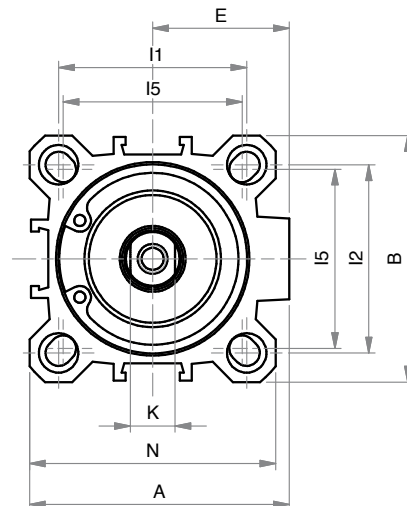
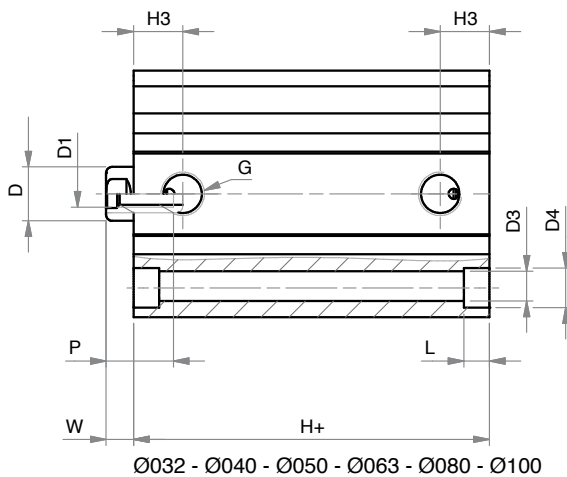
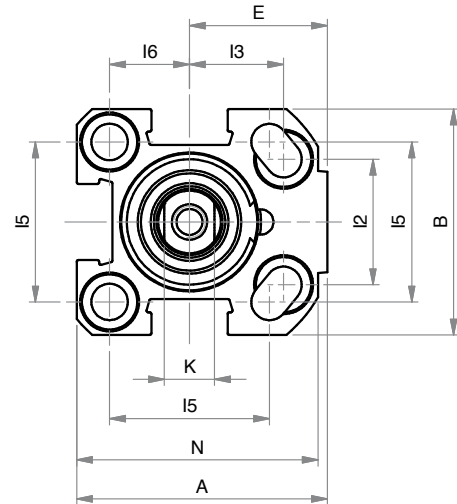
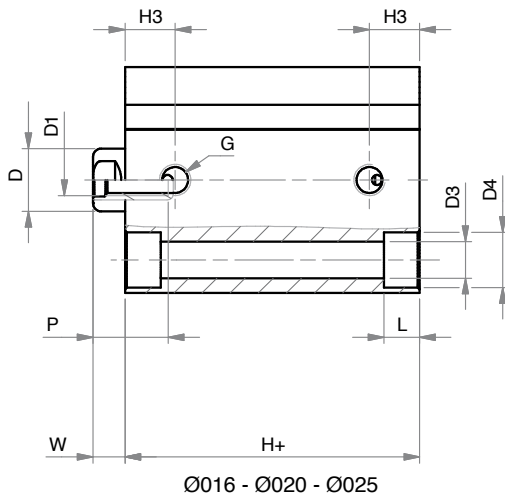



**SEMPLICE EFFETTO MAGNETICO - MOLLA ANTERIORE**
**FSM**
**MAGNETIC SINGLE ACTING - FRONT SPRING**
**DIMENSIONI - DIMENSIONS**

Ø	012	016	020	025	032	040	050	063	080	100
<b>A</b>	25	34	40	44,5	51	58	70	89	105	131
<b>B</b>	25	30	36	40	46	55	65	80	100	124
<b>Ø D</b>	6	8	10	10	12	12	16	16	20	25
<b>D1</b>	M3	M4	M5	M5	M6	M6	M8	M8	M10	M12
<b>Ø D3</b>	3,7	**	5,8	5,8	5,8	5,8	6,8	9	9	11
<b>Ø D4</b>	5,6	**	9	9	9	9	11	14	14	17,2
<b>E</b>	-	19	22	24,5	27	30,5	37,5	46	55	69
<b>G</b>	M5	M5	M5	G1/8	G1/8	G1/8	G1/8	G1/8	G1/4	G1/4
<b>H+</b>	27	32*	32*	38,5*	39,5*	39,5*	39,5*	42*	46*	56*
<b>H3</b>	5,5	8	8	10,5	11,5	11	11,5	11	14	16
<b>I1</b>	15,5	-	-	-	36	42	50	62	82	103
<b>I2</b>	-	18	20	26	32	42	50	62	82	103
<b>I3</b>	-	12	15	15,5	-	-	-	-	-	-
<b>I5</b>	-	20	25,5	28	34	40	50	60	77	94
<b>I6</b>	-	10	12,7	14	-	-	-	-	-	-
<b>K</b>	5	6	8	8	10	10	13	13	17	22
<b>L</b>	3,5	4,6	5,7	5,7	5,7	5,7	6,8	8,8	9	11
<b>L1</b>	-	3,5	5,7	5,7	-	-	-	-	-	-
<b>N</b>	-	32	38,5	42	48	55	65	80	100	124
<b>P</b>	7	11	12	12	15	15	17	17	17	22
<b>W</b>	3,5	4,5	4,5	5,5	5,5	6,5	7,5	6,5	8	10

+ = aggiungere lunghezza corsa (mm) - add stroke length (mm)

\* per corse - for strokes 025:

Ø 016-020 aggiungere - add +6 mm

Ø 025 aggiungere - add +1 mm

\* per corse - for strokes 040-050:

Ø 032-040-050-063-080-100 aggiungere - add +10 mm

\*\* vedi quote pagina 157 - see dimensions page 157

Ø	CORSE STANDARD - STANDARD STROKES
<b>012</b>	5 - 10
<b>016</b>	5 - 10 - 15
<b>020</b>	5 - 10 - 15 - 20 - 25
<b>025</b>	5 - 10 - 15 - 20 - 25
<b>032</b>	5 - 10 - 15 - 20 - 25 - 30 - 40 - 50
<b>040</b>	5 - 10 - 15 - 20 - 25 - 30 - 40 - 50
<b>050</b>	10 - 15 - 20 - 25 - 30 - 40 - 50
<b>063</b>	10 - 15 - 20 - 25 - 30 - 40 - 50
<b>080</b>	10 - 15 - 20 - 25 - 30 - 40 - 50
<b>100</b>	10 - 15 - 20 - 25 - 30 - 40 - 50

!!!: Le corse intermedie vengono realizzate con il corpo della corsa standard superiore e con distanziale interno per limitarne la corsa a quella richiesta.

Intermediate strokes are made with the profile of the standard superior stroke and with an internal spacer which limits the stroke to the required one.

SERIE

**F**

**SEMPLICE EFFETTO (MAGNETICO) - MOLLA POSTERIORE**

FSE

FSEM

**SINGLE ACTING (MAGNETIC) - REAR SPRING**

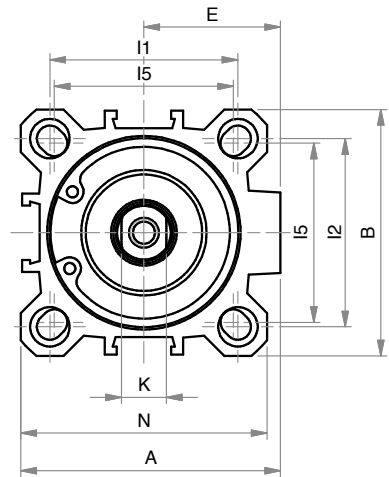
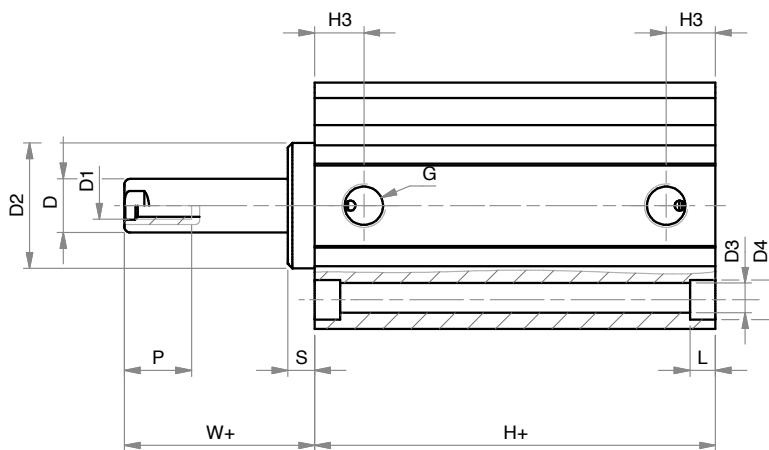
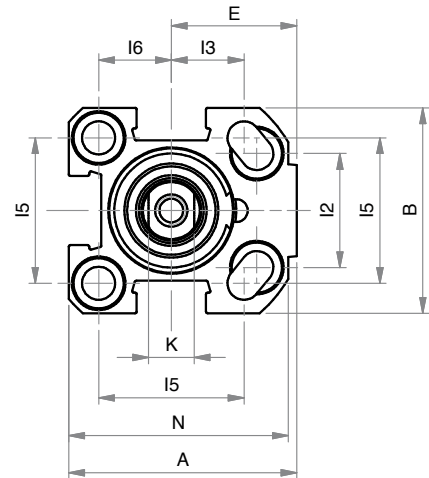
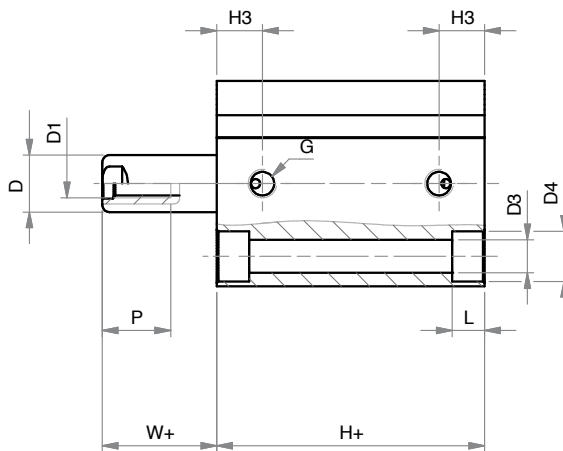
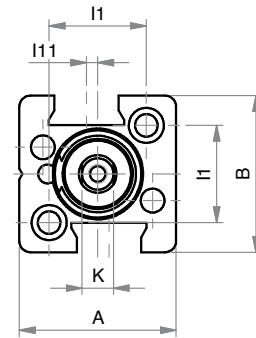
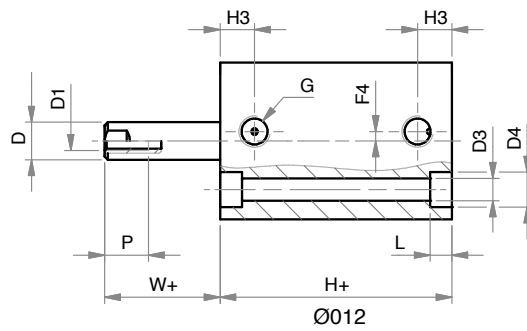
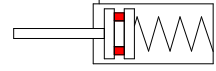
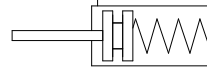

SERIE

F

**SEMPLICE EFFETTO (MAGNETICO) - MOLLA POSTERIORE**
**FSE**
**FSEM**
**SINGLE ACTING (MAGNETIC) - REAR SPRING**

<b>DIMENSIONI - DIMENSIONS</b>								
<b>Ø</b>	<b>012</b>	<b>016</b>	<b>020</b>	<b>025</b>	<b>032</b>	<b>040</b>	<b>050</b>	<b>063</b>
<b>A</b>	25	34	40	44,5	51	58	70	89
<b>B</b>	25	30	36	40	46	55	65	80
<b>Ø D</b>	6	8	10	10	12	12	16	16
<b>D1</b>	M3	M4	M5	M5	M6	M6	M8	M8
<b>Ø D2</b>	-	-	-	-	24,5	28	34	38,5
<b>Ø D3</b>	3,7	**	5,8	5,8	5,8	5,8	6,8	9
<b>Ø D4</b>	5,6	**	9	9	9	9	11	14
<b>E</b>	-	19	22	24,5	27	30,5	37,5	46
<b>G</b>	M5	M5	M5	G1/8	G1/8	G1/8	G1/8	G1/8
<b>H+</b>	***	32*	32*	38,5*	39,5	39,5	39,5	42
<b>H3</b>	5,5	8	8	10,5	11,5	11	11,5	11
<b>I1</b>	15,5	-	-	-	36	42	50	62
<b>I2</b>	-	18	20	26	32	42	50	62
<b>I3</b>	-	12	15	15,5	-	-	-	-
<b>I5</b>	-	20	25,5	28	34	40	50	60
<b>I6</b>	-	10	12,7	14	-	-	-	-
<b>K</b>	5	6	8	8	10	10	13	13
<b>L</b>	3,5	4,6	5,7	5,7	5,7	5,7	6,8	8,8
<b>L1</b>	-	3,5	5,7	5,7	-	-	-	-
<b>N</b>	-	32	38,5	42	48	55	65	80
<b>P</b>	7	11	12	12	15	15	17	17
<b>S</b>	-	-	-	-	5	6	6	8
<b>W+</b>	3,5	4,5	4,5	5,5	11	12,5	13,5	15

+ = aggiungere lunghezza corsa (mm) - add stroke length (mm)

\* per corse - for strokes 020-025:

Ø 020 aggiungere - add +11 mm

Ø 025 aggiungere - add +6 mm

Ø 032 aggiungere - add +5 mm

\* per corsa - for stroke 030:

Ø 032 aggiungere - add +10 mm

\*\* vedi quote pagina pagina 157 - see dimensions page 157

\*\*\* FSE=17 - FSEM=27

<b>Ø</b>	<b>CORSE STANDARD - STANDARD STROKES</b>
<b>012</b>	5 - 10
<b>016</b>	5 - 10 - 15
<b>020</b>	5 - 10 - 15 - 20 - 25
<b>025</b>	5 - 10 - 15 - 20 - 25
<b>032</b>	5 - 10 - 15 - 20 - 25 - 30
<b>040</b>	10 - 15 - 20 - 25 - 30
<b>050</b>	10 - 15 - 20 - 25 - 30
<b>063</b>	10 - 15 - 20 - 25 - 30

!!!: Le corse intermedie vengono realizzate con il corpo della corsa standard superiore e con distanziale interno per limitarne la corsa a quella richiesta.

Intermediate strokes are made with the profile of the standard superior stroke and with an internal spacer which limits the stroke to the required one.

SERIE

**F**

**DOPPIO EFFETTO**

**DOUBLE ACTING**

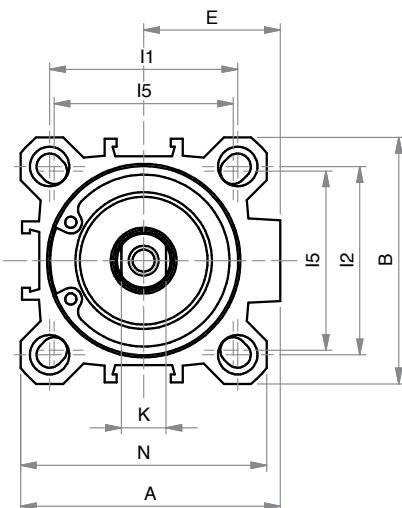
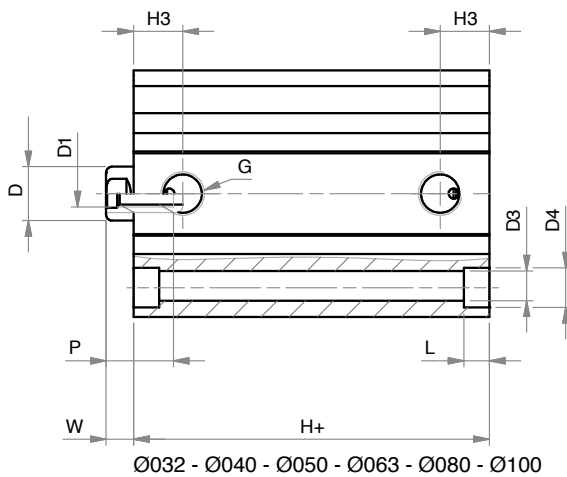
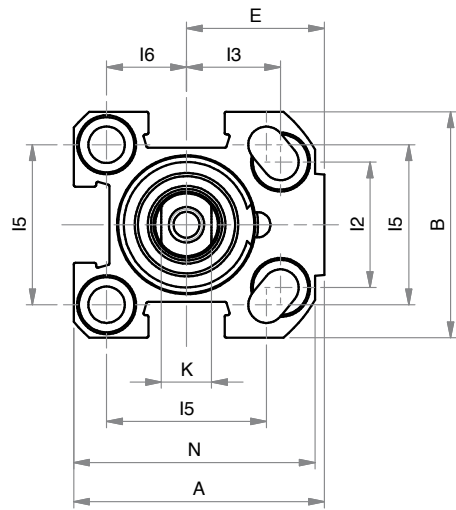
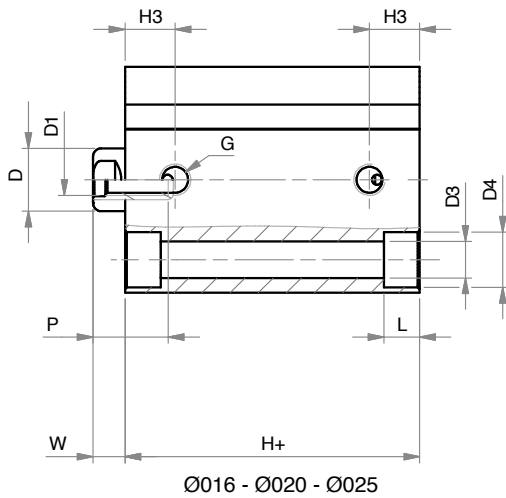
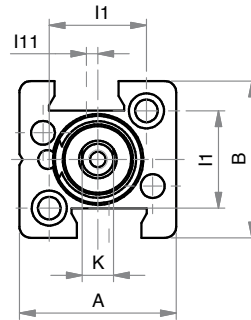
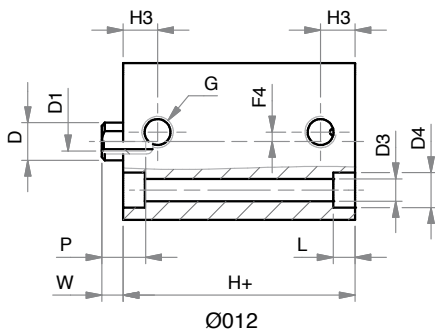
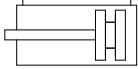

SERIE  
**F**

**DOPPIO EFFETTO**
**FDR**
**DOUBLE ACTING**

<b>DIMENSIONI - DIMENSIONS</b>										
<b>Ø</b>	<b>012</b>	<b>016</b>	<b>020</b>	<b>025</b>	<b>032</b>	<b>040</b>	<b>050</b>	<b>063</b>	<b>080</b>	<b>100</b>
<b>A</b>	25	34	40	44,5	51	58	70	89	105	131
<b>B</b>	25	30	36	40	46	55	65	80	100	124
<b>Ø D</b>	6	8	10	10	12	12	16	16	20	25
<b>D1</b>	M3	M4	M5	M5	M6	M6	M8	M8	M10	M12
<b>Ø D3</b>	3,7	**	5,8	5,8	5,8	5,8	6,8	9	9	11
<b>Ø D4</b>	5,6	**	9	9	9	9	11	14	14	17,2
<b>E</b>	-	19	22	24,5	27	30,5	37,5	46	55	69
<b>G</b>	M5	M5	M5	G1/8	G1/8	G1/8	G1/8	G1/8	G1/4	G1/4
<b>H+</b>	17	27*	27*	28,5*	29,5	29,5	34,5	37	46	56
<b>H3</b>	5,5	8	8	10,5	11,5	11	11,5	11	14	16
<b>I1</b>	15,5	-	-	-	36	42	50	62	82	103
<b>I2</b>	-	18	20	26	32	42	50	62	82	103
<b>I3</b>	-	12	15	15,5	-	-	-	-	-	-
<b>I5</b>	-	20	25,5	28	34	40	50	60	77	94
<b>I6</b>	-	10	12,7	14	-	-	-	-	-	-
<b>K</b>	5	6	8	8	10	10	13	13	17	22
<b>L</b>	3,5	4,6	5,7	5,7	5,7	5,7	6,8	8,8	9	11
<b>L1</b>	-	3,5	5,7	5,7	-	-	-	-	-	-
<b>N</b>	-	32	38,5	42	48	55	65	80	100	124
<b>P</b>	7	11	12	12	15	15	17	17	17	22
<b>W</b>	3,5	4,5	5	5,5	6	6	7,5	7	8	10

+ = aggiungere lunghezza corsa (mm) - *add stroke length (mm)*

\* per corse - *for strokes 030-040-050:*

Ø 016-020 aggiungere - *add +1 mm*

\* per corse - *for strokes 040-050:*

Ø 025 aggiungere - *add +1 mm*

\*\* vedi quote pagina 157 - *see dimensions page 157*

<b>Ø</b>	<b>CORSE STANDARD - STANDARD STROKES</b>
<b>012</b>	5 - 10 - 15 - 20 - 25 - 30 - 40 - 50
<b>016</b>	5 - 10 - 15 - 20 - 25 - 30 - 40 - 50
<b>020</b>	5 - 10 - 15 - 20 - 25 - 30 - 40 - 50
<b>025</b>	5 - 10 - 15 - 20 - 25 - 30 - 40 - 50
<b>032</b>	5 - 10 - 15 - 20 - 25 - 30 - 40 - 50 - 60 - 80 - 100
<b>040</b>	5 - 10 - 15 - 20 - 25 - 30 - 40 - 50 - 60 - 80 - 100
<b>050</b>	10 - 15 - 20 - 25 - 30 - 40 - 50 - 60 - 80 - 100
<b>063</b>	10 - 15 - 20 - 25 - 30 - 40 - 50 - 60 - 80 - 100
<b>080</b>	10 - 15 - 20 - 25 - 30 - 40 - 50 - 60 - 80 - 100 - 125 - 160 - 200 - 250
<b>100</b>	10 - 15 - 20 - 25 - 30 - 40 - 50 - 60 - 80 - 100 - 125 - 160 - 200 - 250

!!!: Le corse intermedie vengono realizzate con il corpo della corsa standard superiore e con distanziale interno per limitarne la corsa a quella richiesta.

*Intermediate strokes are made with the profile of the standard superior stroke and with an internal spacer which limits the stroke to the required one.*

SERIE

**F**

**DOPPIO EFFETTO MAGNETICO**

**DOUBLE ACTING MAGNETIC**

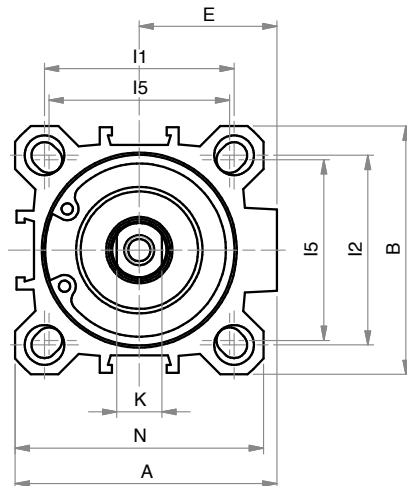
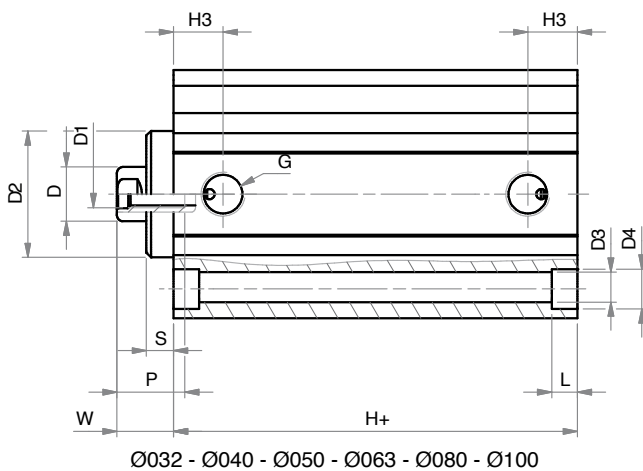
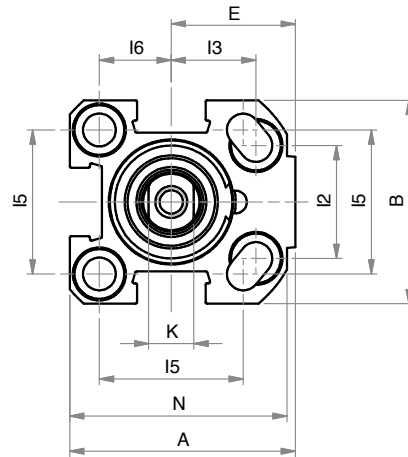
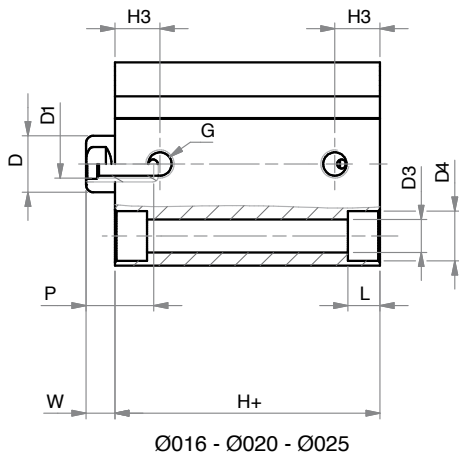
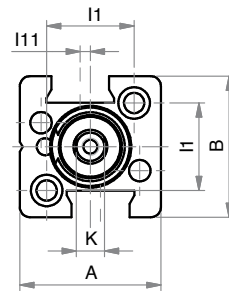
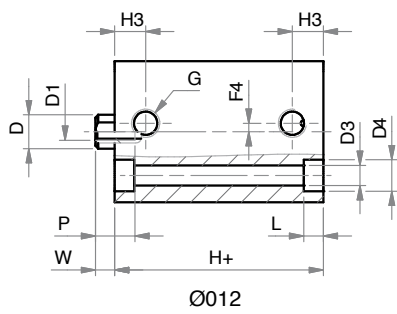
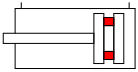

**DOPPIO EFFETTO MAGNETICO**
**DOUBLE ACTING MAGNETIC**

<b>DIMENSIONI - DIMENSIONS</b>										
<b>Ø</b>	<b>012</b>	<b>016</b>	<b>020</b>	<b>025</b>	<b>032</b>	<b>040</b>	<b>050</b>	<b>063</b>	<b>080</b>	<b>100</b>
<b>A</b>	25	34	40	44,5	51	58	70	89	105	131
<b>B</b>	25	30	36	40	46	55	65	80	100	124
<b>Ø D</b>	6	8	10	10	12	12	16	16	20	25
<b>D1</b>	M3	M4	M5	M5	M6	M6	M8	M8	M10	M12
<b>Ø D2</b>	-	-	-	-	24,5	28	34	38,5	44	56
<b>Ø D3</b>	3,7	**	5,8	5,8	5,8	5,8	6,8	9	9	11
<b>Ø D4</b>	5,6	**	9	9	9	9	11	14	14	17,2
<b>E</b>	-	19	22	24,5	27	30,5	37,5	46	55	69
<b>G</b>	M5	M5	M5	G1/8	G1/8	G1/8	G1/8	G1/8	G1/4	G1/4
<b>H+</b>	27	32*	32*	38,5*	39,5	39,5	39,5	42	46	56
<b>H3</b>	5,5	8	8	10,5	11,5	11	11,5	11	14	16
<b>I1</b>	15,5	-	-	-	36	42	50	62	82	103
<b>I2</b>	-	18	20	26	32	42	50	62	82	103
<b>I3</b>	-	12	15	15,5	-	-	-	-	-	-
<b>I5</b>	-	20	25,5	28	34	40	50	60	77	94
<b>I6</b>	-	10	12,7	14	-	-	-	-	-	-
<b>K</b>	5	6	8	8	10	10	13	13	17	22
<b>L</b>	3,5	4,6	5,7	5,7	5,7	5,7	6,8	8,8	9	11
<b>L1</b>	-	3,5	5,7	5,7	-	-	-	-	-	-
<b>N</b>	-	32	38,5	42	48	55	65	80	100	124
<b>P</b>	7	11	12	12	15	15	17	17	17	22
<b>S</b>	-	-	-	-	5	6	6	8	10	10,5
<b>W</b>	3,5	4,5	4,5	5,5	11	12,5	13,5	15	18	20,5

+ = aggiungere lunghezza corsa (mm) - add stroke length (mm)

\* per corse - for strokes >= 025:

Ø 016-020 aggiungere - add +6 mm

Ø 025 aggiungere - add +1 mm

\*\* vedi quote pagina 157 - see dimensions page 157

<b>Ø</b>	<b>CORSE STANDARD - STANDARD STROKES</b>
<b>012</b>	5 - 10 - 15 - 20 - 25 - 30 - 40
<b>016</b>	5 - 10 - 15 - 20 - 25 - 30 - 40 - 50 - 60 - 80 - 100
<b>020</b>	5 - 10 - 15 - 20 - 25 - 30 - 40 - 50 - 60 - 80 - 100 - 125
<b>025</b>	5 - 10 - 15 - 20 - 25 - 30 - 40 - 50 - 60 - 80 - 100 - 125
<b>032</b>	5 - 10 - 15 - 20 - 25 - 30 - 40 - 50 - 60 - 80 - 100 - 125 - 160
<b>040</b>	5 - 10 - 15 - 20 - 25 - 30 - 40 - 50 - 60 - 80 - 100 - 125 - 160
<b>050</b>	10 - 15 - 20 - 25 - 30 - 40 - 50 - 60 - 80 - 100 - 125 - 160 - 200
<b>063</b>	10 - 15 - 20 - 25 - 30 - 40 - 50 - 60 - 80 - 100 - 125 - 160 - 200
<b>080</b>	10 - 15 - 20 - 25 - 30 - 40 - 50 - 60 - 80 - 100 - 125 - 160 - 200 - 250
<b>100</b>	10 - 15 - 20 - 25 - 30 - 40 - 50 - 60 - 80 - 100 - 125 - 160 - 200 - 250

!!!: Le corse intermedie vengono realizzate con il corpo della corsa standard superiore e con distanziale interno per limitarne la corsa a quella richiesta.

Intermediate strokes are made with the profile of the standard superior stroke and with an internal spacer which limits the stroke to the required one.

**DOPPIO EFFETTO (MAGNETICO) ANTIROTAZIONE**

FDA

FDMA

**DOUBLE ACTING (MAGNETIC) ANTI-ROTATION**

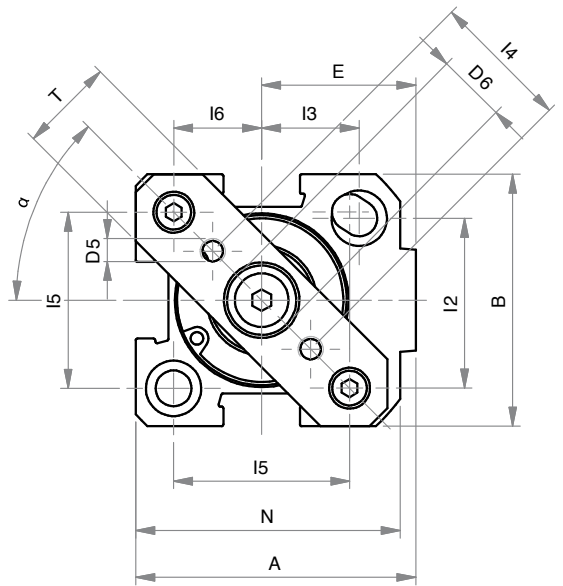
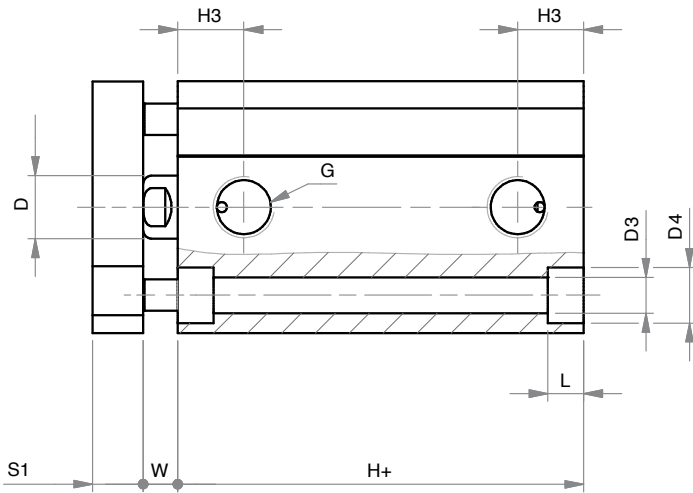
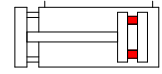
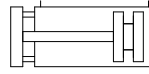

Ø020 - Ø025

SERIE  
**F**

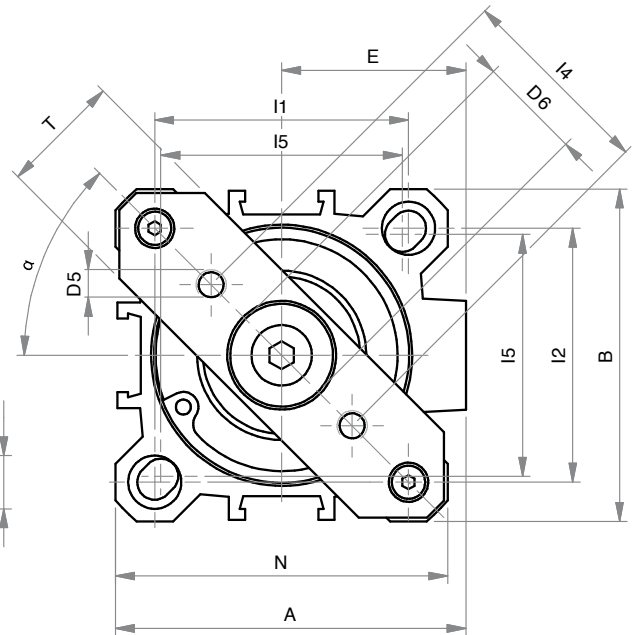
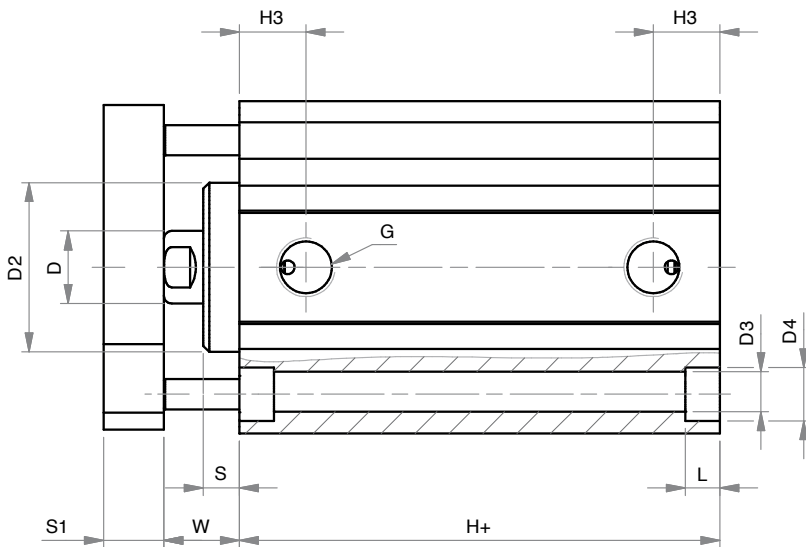

Ø032 - Ø040 - Ø050 - Ø063 - Ø080 - Ø100



**DOPPIO EFFETTO (MAGNETICO) ANTIROTAZIONE**
**FDA**
**FDMA**
**DOUBLE ACTING (MAGNETIC) ANTI-ROTATION**

<b>DIMENSIONI - DIMENSIONS</b>								
<b>Ø</b>	<b>020</b>	<b>025</b>	<b>032</b>	<b>040</b>	<b>050</b>	<b>063</b>	<b>080</b>	<b>100</b>
<b>A</b>	40	44,5	51	58	70	89	105	131
<b>B</b>	36	40	46	55	65	80	100	124
<b>α</b>	45°	45°	41,5°	45°	45°	45°	45°	45°
<b>Ø D</b>	10	10	12	12	16	16	20	25
<b>Ø D2</b>	-	-	24,5	28	34	38,5	44	56
<b>Ø D3</b>	5,8	5,8	5,8	5,8	6,8	9	9	11
<b>Ø D4</b>	9	9	9	9	11	14	14	17,2
<b>D5</b>	M4	M4	M5	M5	M6	M6	M8	M10
<b>Ø D6</b>	11	11	17	17	22	22	28	30
<b>E</b>	22	24,5	27	30,5	37,5	46	55	69
<b>G</b>	M5	G1/8	G1/8	G1/8	G1/8	G1/8	G1/4	G1/4
<b>H+</b>	32*	38,5*	39,5	39,5	39,5	42	46	56
<b>H3</b>	8	10,5	11,5	11	11,5	11	14	16
<b>I1</b>	-	-	36	42	50	62	82	103
<b>I2</b>	20	26	32	42	50	62	82	103
<b>I3</b>	15	15,5	-	-	-	-	-	-
<b>I4</b>	20	22	28	33	42	50	65	80
<b>I5</b>	25,5	28	34	40	50	60	77	94
<b>I6</b>	12,7	14	-	-	-	-	-	-
<b>K</b>	8	8	10	10	13	13	17	22
<b>L</b>	5,7	5,7	5,7	5,7	6,8	8,8	9	11
<b>L1</b>	5,7	5,7	-	-	-	-	-	-
<b>N</b>	38,5	42	48	55	65	80	100	124
<b>S</b>	-	-	5	6	6	8	10	10,5
<b>S1</b>	8	8	10	10	12	12	14	14
<b>T</b>	15	15	20	20	30	30	50	50
<b>W</b>	4,5	5,5	11	12,5	13,5	15	18	20,5

+ = aggiungere lunghezza corsa (mm) - add stroke length (mm)

\* per corse - for strokes >= 025:

Ø 020 aggiungere - add +6 mm

Ø 025 aggiungere - add +1 mm

<b>Ø</b>	<b>CORSE STANDARD - STANDARD STROKES</b>
<b>020</b>	5 - 10 - 15 - 20 - 25 - 30 - 40 - 50 - 60 - 80 - 100 - 125
<b>025</b>	5 - 10 - 15 - 20 - 25 - 30 - 40 - 50 - 60 - 80 - 100 - 125
<b>032</b>	5 - 10 - 15 - 20 - 25 - 30 - 40 - 50 - 60 - 80 - 100 - 125
<b>040</b>	5 - 10 - 15 - 20 - 25 - 30 - 40 - 50 - 60 - 80 - 100 - 125
<b>050</b>	10 - 15 - 20 - 25 - 30 - 40 - 50 - 60 - 80 - 100 - 125
<b>063</b>	10 - 15 - 20 - 25 - 30 - 40 - 50 - 60 - 80 - 100 - 125 - 160
<b>080</b>	10 - 15 - 20 - 25 - 30 - 40 - 50 - 60 - 80 - 100 - 125 - 160
<b>100</b>	10 - 15 - 20 - 25 - 30 - 40 - 50 - 60 - 80 - 100 - 125 - 160
<b>080</b>	10 - 15 - 20 - 25 - 30 - 40 - 50 - 60 - 80 - 100 - 125 - 160 - 200 - 250
<b>100</b>	10 - 15 - 20 - 25 - 30 - 40 - 50 - 60 - 80 - 100 - 125 - 160 - 200 - 250

!!!: Le corse intermedie vengono realizzate con il corpo della corsa standard superiore e con distanziale interno per limitarne la corsa a quella richiesta.

Intermediate strokes are made with the profile of the standard superior stroke and with an internal spacer which limits the stroke to the required one.

**SERIE**
**F**

**DOPPIO EFFETTO (MAGNETICO) STELO PASSANTE**

FDP

FDMP

**DOUBLE ACTING (MAGNETIC) WITH DOUBLE ROD**

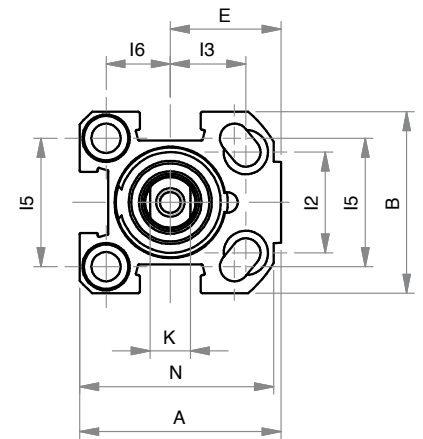
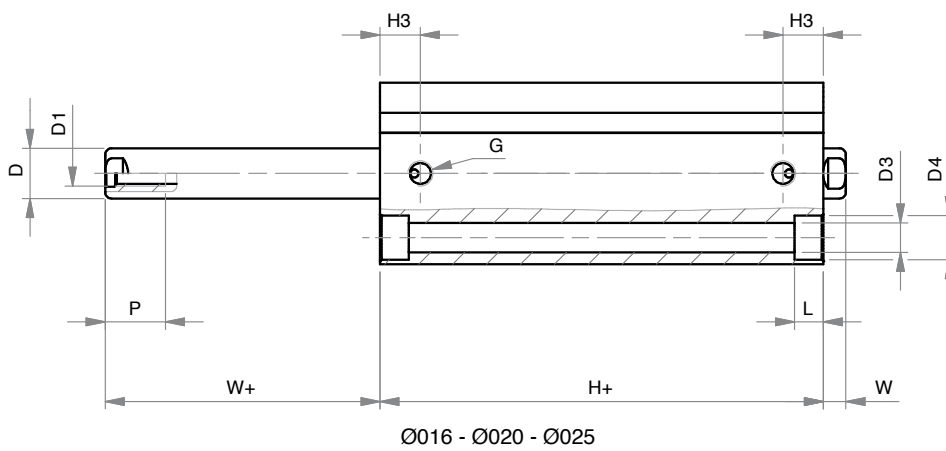
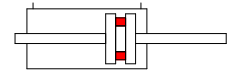
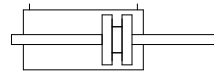

SERIE

F

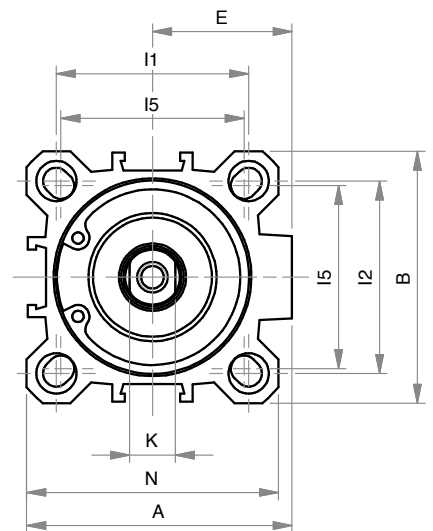
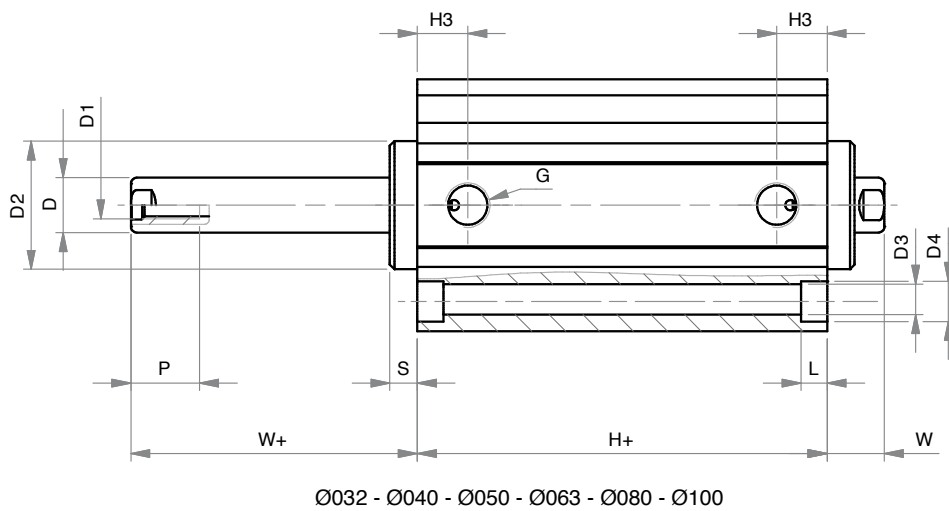

**DOPPIO EFFETTO (MAGNETICO) STELO PASSANTE**
**FDP**
**FDMP**
**DOUBLE ACTING (MAGNETIC) WITH DOUBLE ROD**

<b>DIMENSIONI - DIMENSIONS</b>									
<b>Ø</b>	<b>016</b>	<b>020</b>	<b>025</b>	<b>032</b>	<b>040</b>	<b>050</b>	<b>063</b>	<b>080</b>	<b>100</b>
<b>A</b>	34	40	44,5	51	58	70	89	105	131
<b>B</b>	30	36	40	46	55	65	80	100	124
<b>Ø D</b>	8	10	10	12	12	16	16	20	25
<b>D1</b>	M4	M5	M5	M6	M6	M8	M8	M10	M12
<b>Ø D2</b>	-	-	-	24,5	28	34	38,5	44	56
<b>Ø D3</b>	**	5,8	5,8	5,8	5,8	6,8	9	9	11
<b>Ø D4</b>	**	9	9	9	9	11	14	14	17,2
<b>E</b>	19	22	24,5	27	30,5	37,5	46	55	69
<b>G</b>	M5	M5	G1/8	G1/8	G1/8	G1/8	G1/8	G1/4	G1/4
<b>H+</b>	32*	32*	38,5*	39,5	39,5	39,5	42	46	56
<b>H3</b>	8	8	10,5	11,5	11	11,5	11	14	16
<b>I1</b>	-	-	-	36	42	50	62	82	103
<b>I2</b>	18	20	26	32	42	50	62	82	103
<b>I3</b>	12	15	15,5	-	-	-	-	-	-
<b>I5</b>	20	25,5	28	34	40	50	60	77	94
<b>I6</b>	10	12,7	14	-	-	-	-	-	-
<b>K</b>	6	8	8	10	10	13	13	17	22
<b>L</b>	4,6	5,7	5,7	5,7	5,7	6,8	8,8	9	11
<b>L1</b>	3,5	5,7	5,7	-	-	-	-	-	-
<b>N</b>	32	38,5	42	48	55	65	80	100	124
<b>P</b>	11	12	12	15	15	17	17	17	22
<b>S</b>	-	-	-	5	6	6	8	10	10,5
<b>W</b>	4,5	4,5	5,5	11	12,5	13,5	15	18	20,5
<b>W+</b>	4,5	4,5	5,5	11	12,5	13,5	15	18	20,5

+ = aggiungere lunghezza corsa (mm) - add stroke length (mm)

\* per corse - for strokes >= 025:

Ø 016-020 aggiungere - add +6 mm

Ø 025 aggiungere - add +1 mm

\*\* vedi quote pagina 157 - see dimensions page 157

<b>Ø</b>	<b>CORSE STANDARD - STANDARD STROKES</b>
<b>016</b>	5 - 10 - 15 - 20 - 25 - 30 - 40 - 50 - 60 - 80 - 100
<b>020</b>	5 - 10 - 15 - 20 - 25 - 30 - 40 - 50 - 60 - 80 - 100 - 125
<b>025</b>	5 - 10 - 15 - 20 - 25 - 30 - 40 - 50 - 60 - 80 - 100 - 125
<b>032</b>	5 - 10 - 15 - 20 - 25 - 30 - 40 - 50 - 60 - 80 - 100 - 125 - 160
<b>040</b>	5 - 10 - 15 - 20 - 25 - 30 - 40 - 50 - 60 - 80 - 100 - 125 - 160
<b>050</b>	10 - 15 - 20 - 25 - 30 - 40 - 50 - 60 - 80 - 100 - 125 - 160 - 200
<b>063</b>	10 - 15 - 20 - 25 - 30 - 40 - 50 - 60 - 80 - 100 - 125 - 160 - 200
<b>080</b>	10 - 15 - 20 - 25 - 30 - 40 - 50 - 60 - 80 - 100 - 125 - 160 - 200 - 250
<b>100</b>	10 - 15 - 20 - 25 - 30 - 40 - 50 - 60 - 80 - 100 - 125 - 160 - 200 - 250
<b>100</b>	10 - 15 - 20 - 25 - 30 - 40 - 50 - 60 - 80 - 100 - 125 - 160 - 200 - 250

!!!: Le corse intermedie vengono realizzate con il corpo della corsa standard superiore e con distanziale interno per limitarne la corsa a quella richiesta.

Intermediate strokes are made with the profile of the standard superior stroke and with an internal spacer which limits the stroke to the required one.

**SERIE**
**F**

## ACCESSORI DI FISSAGGIO CILINDRO CORSA BREVE (SERIE F)

### SHORT STROKE CYLINDER MOUNTING PARTS (SERIE F)

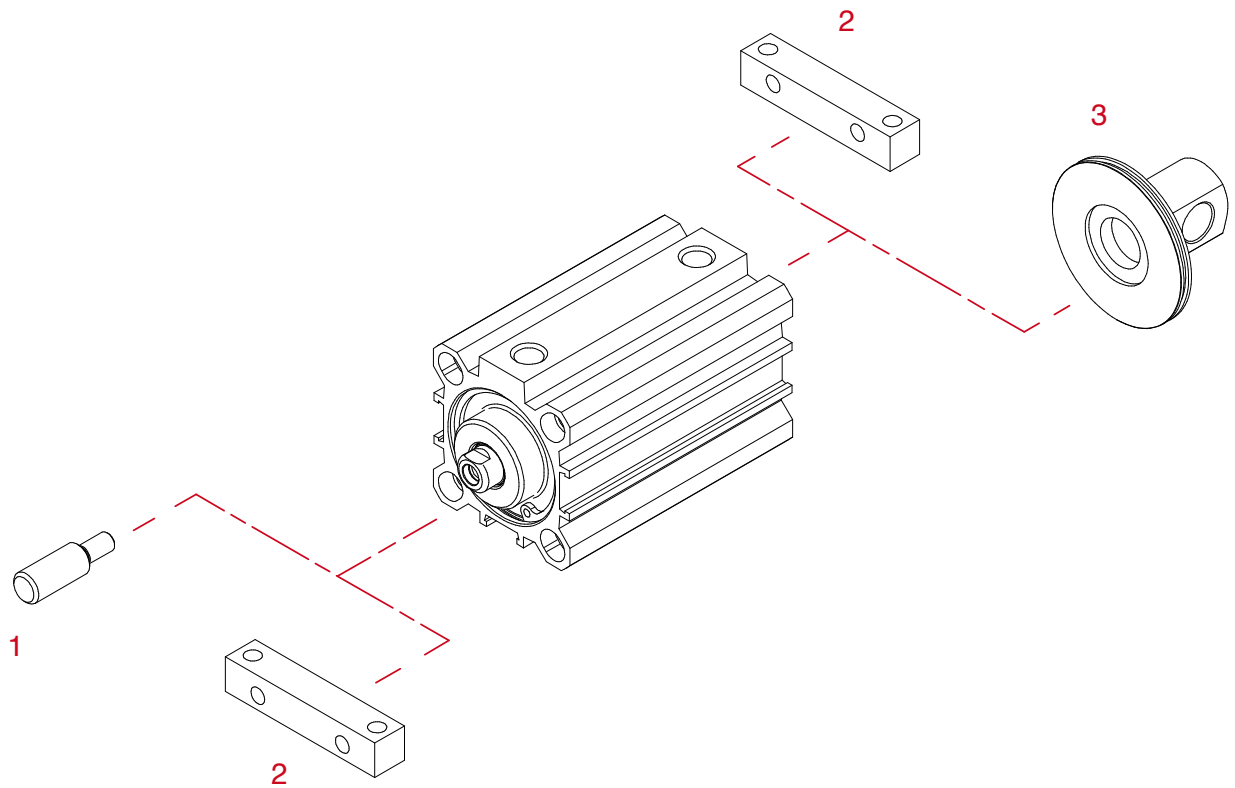

SERIE

**F**

POS.	CODE	DESCRIZIONE-DESCRIPTION
1	<b>NP---</b>	niplo - nipples
2	<b>FPD---</b>	piedino - foot mounting
3	<b>FCP---</b>	cerniera maschio - male hinge

Dimensioni accessori: vedi sezione SERIE W

Accessories dimensions: see SERIE W chapter